

Liverpool John Moores University



Research Institute for Sport & Exercise Sciences
FACULTY OF SCIENCE



Plantar pressure as part of balance evaluation during dynamic sport activities

La presión plantar como parte de la evaluación del equilibrio durante la práctica de actividades deportivas.

Balance?



STATIC

Borelli, 1680

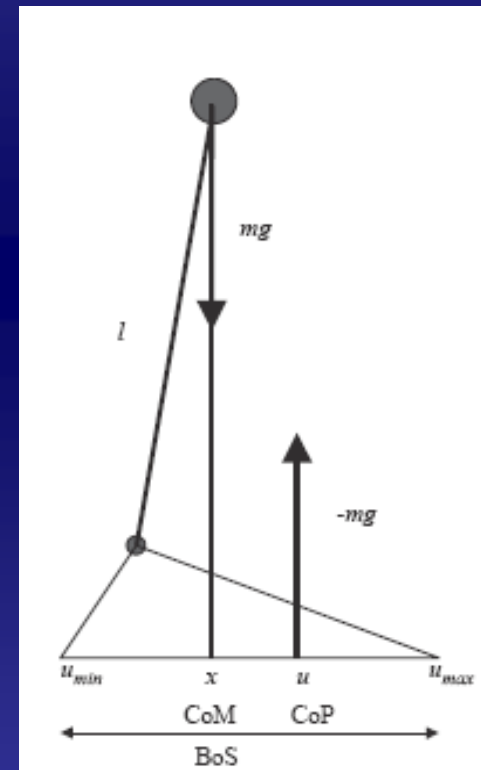

STATIC



- Eyes open vs closed
- Parallel vs tandem
- Two feet vs one foot
- Narrow beam vs foam

DYNAMIC

Hof, 2006, JBiom

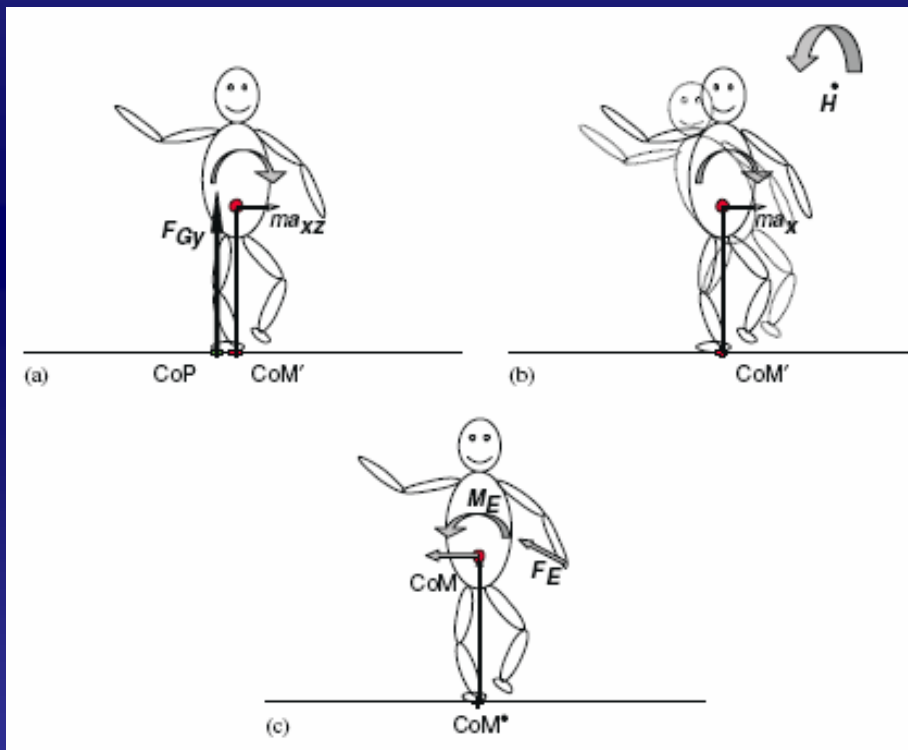

DYNAMIC

- Time to boundary of BoS
 - Pos-vel (Riccio, 1993)
 - Pos-vel-acc (Slobounov, 1997)
- Extrapolated CoM (Hof, 2005)

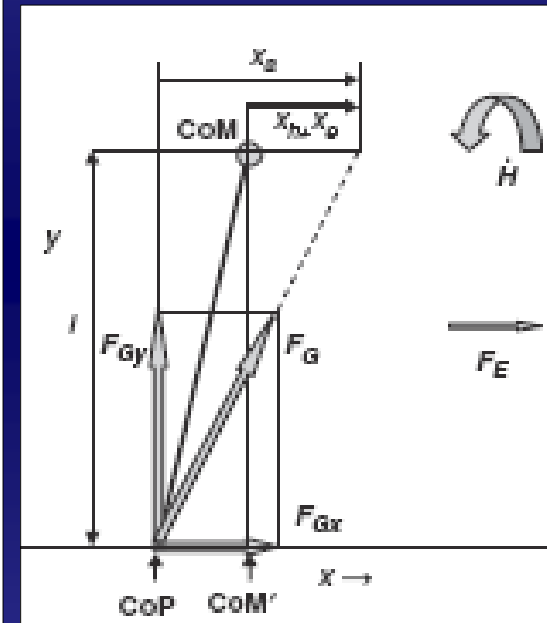
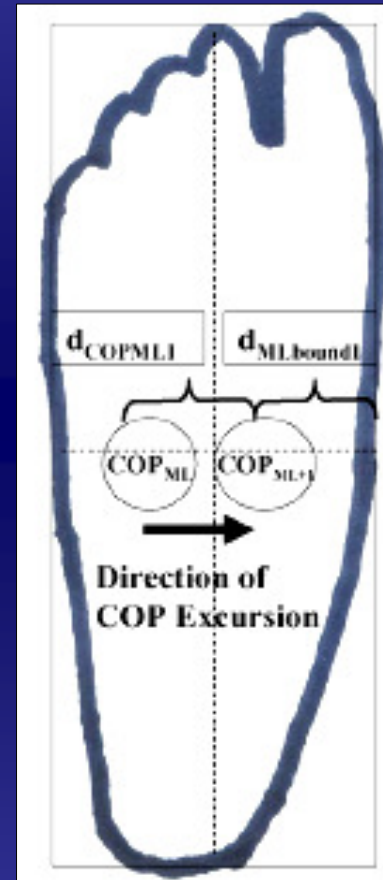

Limitations

- Base of support = static
- Assumptions inverted pendulum:
 - Constant length
 - Small angular deviations

Base of Support - static

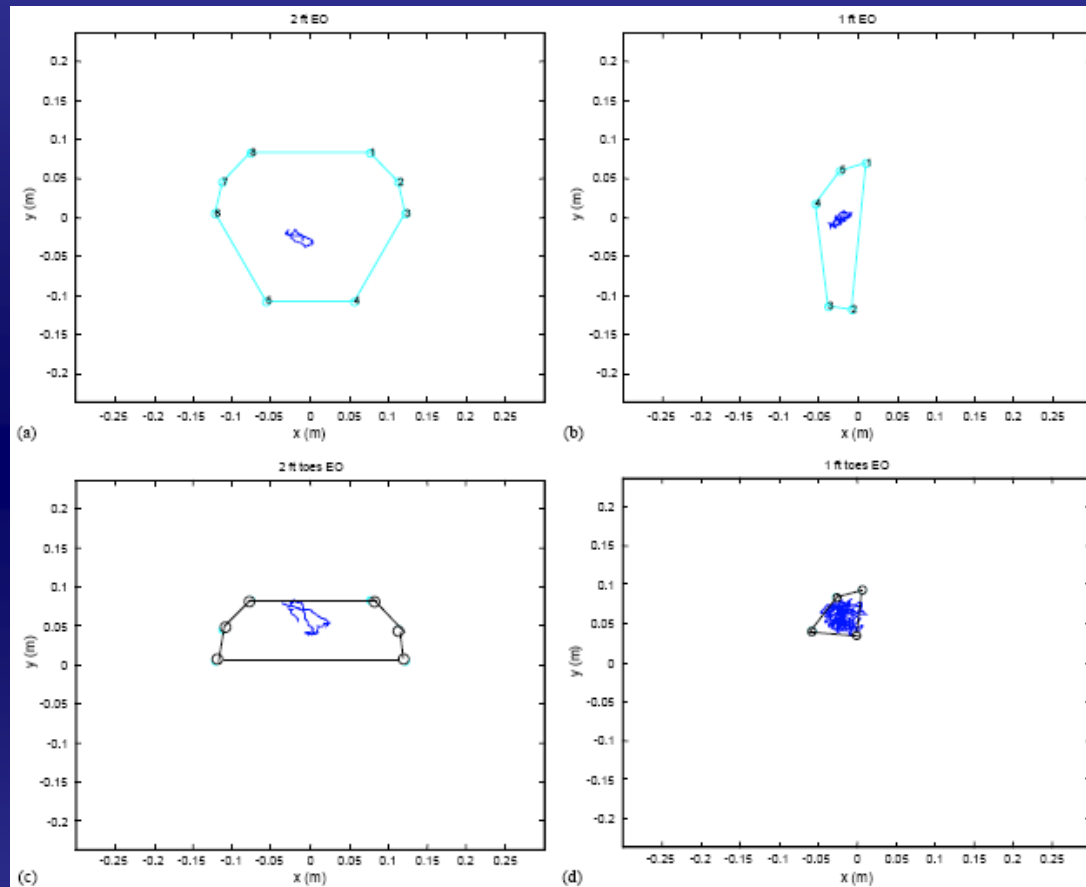
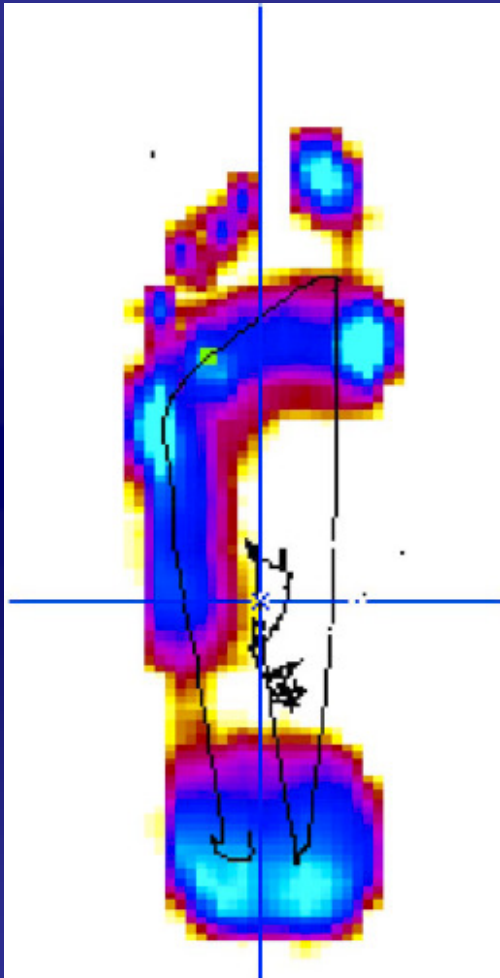

Hof, 2005, JBiom

Standing on one foot – eyes closed

Clip

Pressure
distribution

Standing on one foot – eyes closed

Clip

Base of Support

Standing on one foot – eyes closed

Distance CoP - BoS

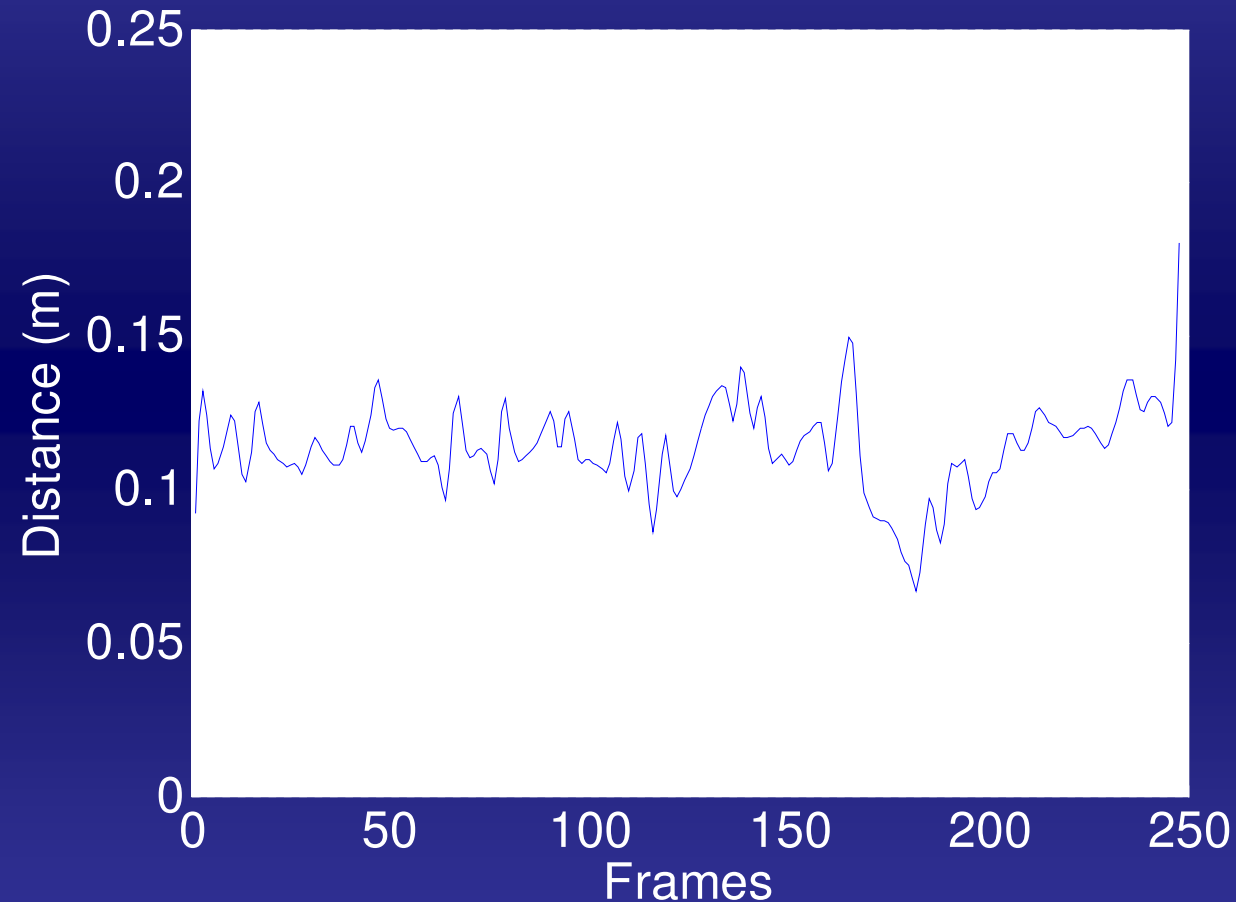

Landing on two feet tiptoe

Clip

Pressure
distribution

Landing on two feet tiptoe

Clip

Base of Support

Landing on two feet tiptoe

Distance CoP - BoS

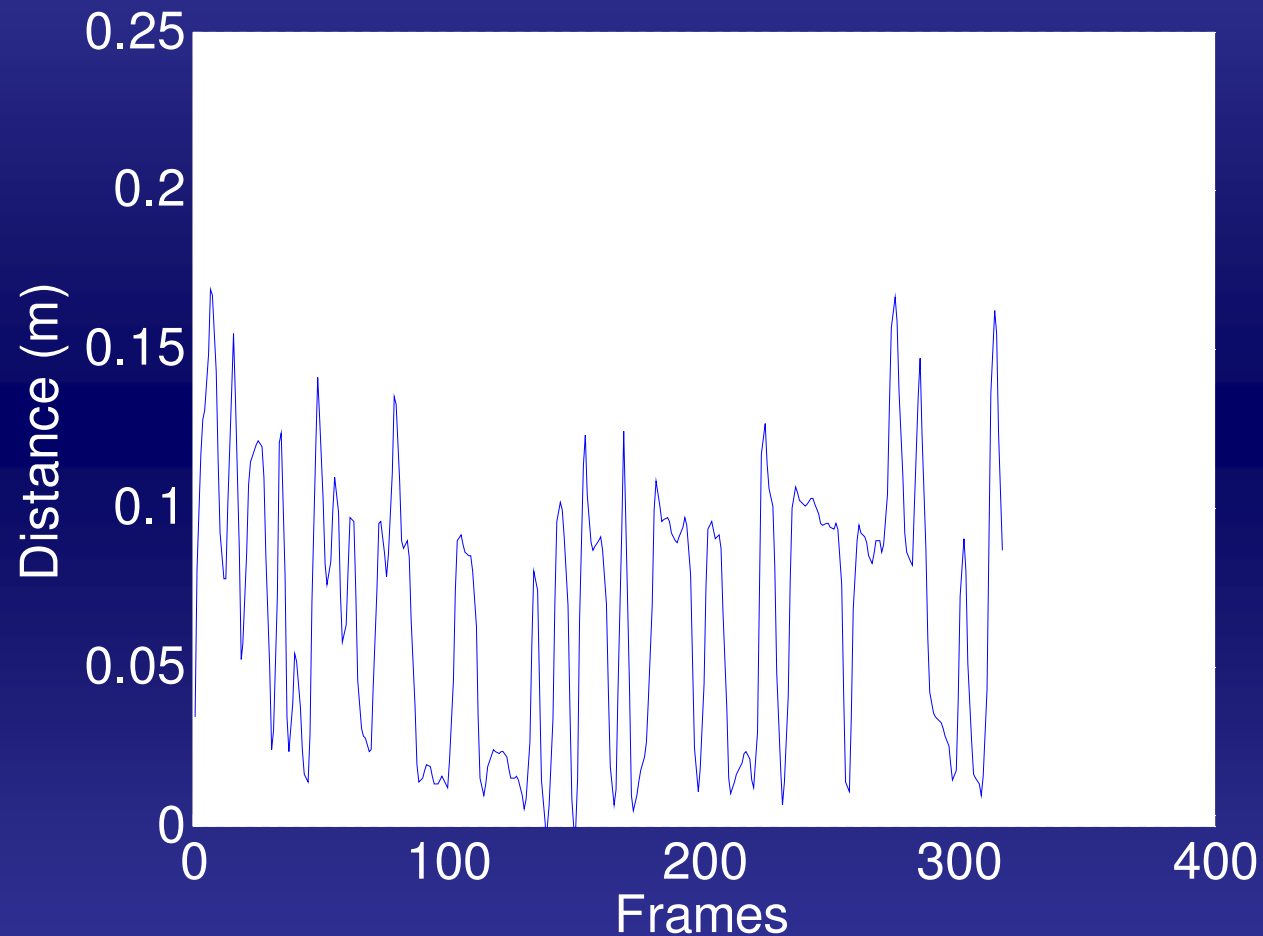

Plantar pressure as part of balance evaluation in dynamic sport activities

- Refinement overall balance evaluation
- Identification role of individual foot structures in balance
 - Functional foottypes (De Cock, 2006)

Team

- Prof. Dr. Lees Adrian
- Dr. Malcolm Hawken
- Khaled Abuzayan



- Dr. Mark Lake
- Dr. Gabor Barton
- Mark Robinson

